

Product

400SD Series

*Sliding Door Lock
CCL R1 Keyway*

*400SD Series
Sliding door lock*

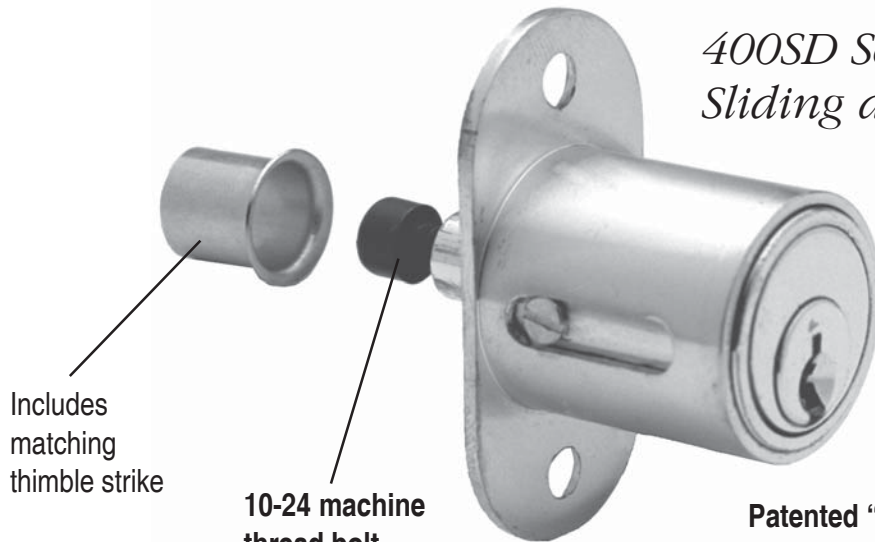

Includes
matching
thimble strike

**10-24 machine
thread bolt
extender** for
varying gaps
between bypassing
doors

**Includes 10-24
machine thread
strike locator** for
determining proper
strike placement

**Patented “speed
release” cylin-
der removal
mechanism** for
quick and easy
rekeying

U.S. Patent Nos.
4,899,563; 4,920,774

Data Sheet

OLYMPUS
LOCK, INC.
The cabinet lock innovators.

18424 Highway 99 • Lynnwood, WA 98037
Phone 206-362-3290 • Toll-free 800-525-0954 • Fax 206-362-3569
www.olympus-lock.com • info@olympus-lock.com

400SD SERIES

Sliding Door Lock National D4291 Keyway



General Specifications

400SD Series sliding door lock

Rekeyable: Easily rekeyable via patented speed release cylinder removal mechanism

Body: Zinc die cast lock body

Bolt: Brass, 3/4" projection

Barrel length: 1"

Barrel diameter: 1"

Finish: US26D (satin chrome) or US3 (polished brass)

Cylinder: CCL R1 keyway

Keying: KD/KA (5 pin standard), stock KA

Nos. 4T2, 4T3. Master keying available (5 pin standard).

includes

- 10-24 machine thread bolt extender for varying gaps between bypassing doors
- 10-24 machine thread strike locator
- Matching thimble strike

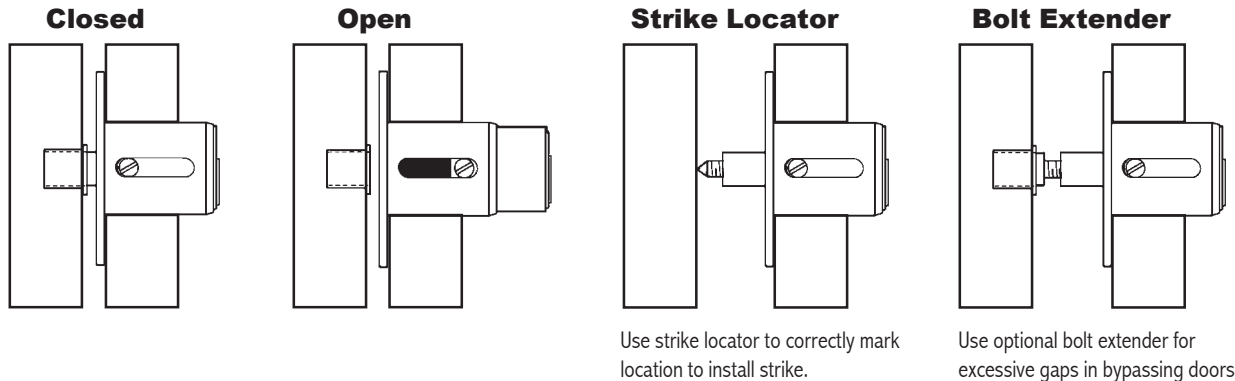

Use strike locator to correctly mark location to install strike.

Use optional bolt extender for excessive gaps in bypassing doors.

400SD Series Dimensions

